

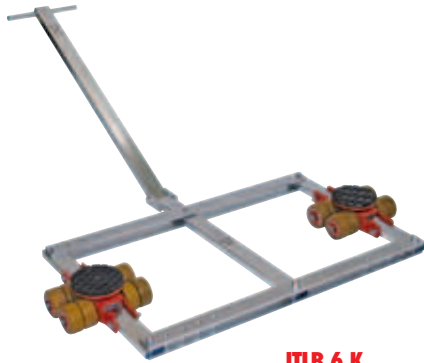

# Transport trolleys Series K professional

For load weights up to 12 metric tons



JTLB 6 K

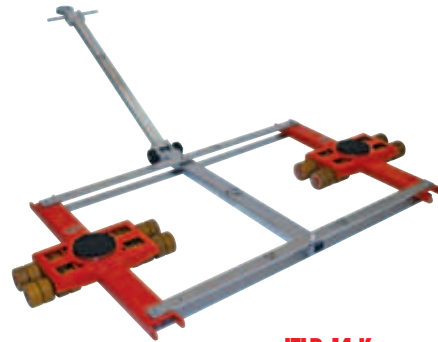

JTLB 14 K

### Available with:

Professional castor  
JUWAthan<sup>®</sup> plus coated aluminium castor



for any floors  
Order number 95 050 089-D

▶ Please refer to page 32-33 for additional roller information

### Advantages in detail

- Galvanized axles and safety clip rings for improved protection against corrosion.
- The double roller design results in dramatically easier steering due to reduced friction forces in curves. The much lower friction resistance also causes the rollers on the rear axis to following in a truer course.
- Tandem transport trolley for loads with no leading or trailing edge centre support.
- Ready for use: 2 interconnected steerable trolleys with 2 handlebars and two tandem connecting rods.
- Multi-purpose use: Also useable as two single trolleys, each with half of the combined load capacity. No additional accessories needed.

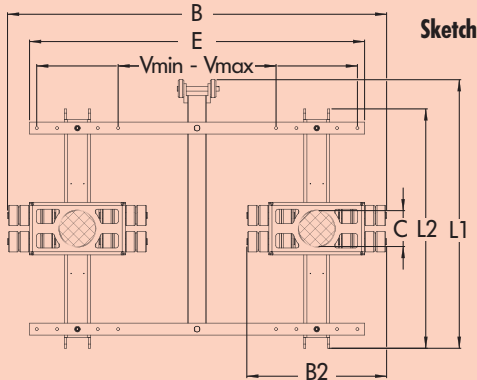

### For short radius curves

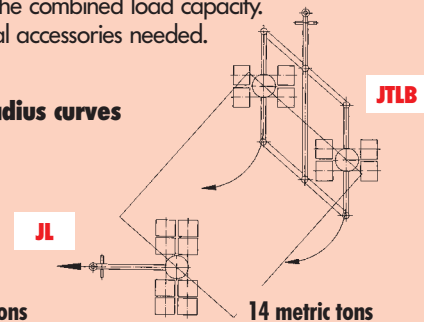

Load weight up to

Type	Sketch		JTLB 6 K	JTLB 14 K
Load capacity		kg / lbs	6 000 / 13 200	14 000 / 30 800
Number of castors		pcs	8	16
Castor dimensions	Ø x l	mm / in	85 x 85 / 3.3 x 3.3"	85 x 85 / 3.3 x 3.3"
Fitting height		mm / in	110 / 4.3"	110 / 4.3"
Cassette dimensions	L2 x B2	mm / in	600 x 280 / 23.6 x 11"	1 000 x 590 / 39.4 x 23.2"
Supporting surface per cassette	Ø C	mm / in	150 / 5.9"	150 / 5.9"
Connecting rod	E	mm / in	1 000 / 39.4"	1 400 / 55.1"
Adjustable from - to Vmin - Vmax.		mm / in	560 - 960* / 22 - 37.3**	600 - 1 340* / 25.9 - 52.7**
Adjustable			5 x	5 x
Total length width	L1 x B1	mm / in	760 x 1 240 / 29.9 x 48.8"	1 070 x 1 580 / 42.1 x 62.1"
Handlebar with pulling eye	Length	mm / in	990** / 39**	1 120 / 44.1"
Weight professional		kg / lbs	37 / 82	104 / 229
Order-no. with professional			12 061 085-D	12 121 085-D

\*other lengths on request \*\*without pulling eye

# Transport trolleys Series G professional

For load weights up to 30 metric tons

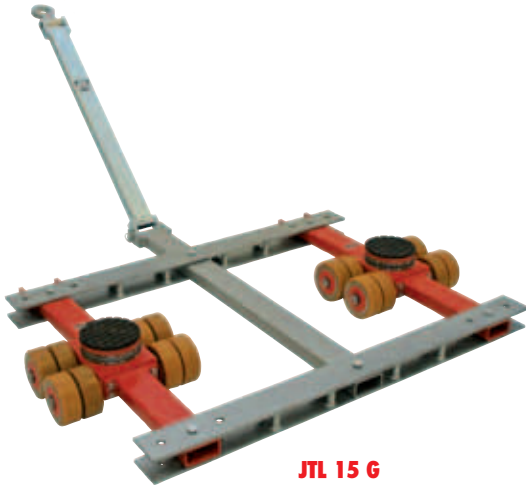

**JTL 15 G**



**JTLB 30 G**

## Available with:

JUWathan® plus-coated aluminium core



for any floors  
Order number 95 050 048-V

▶ Please refer to page 32-33 for additional roller information

Sketch

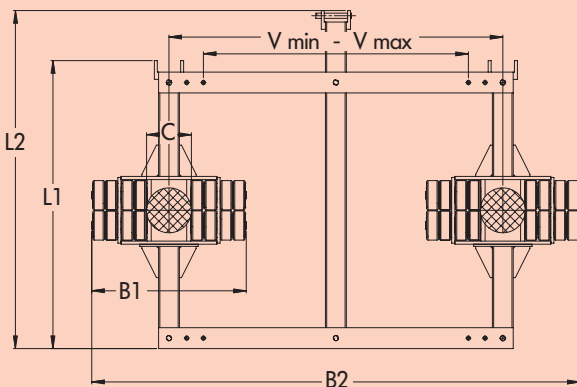

## Advantages in detail

- Large rollers warrant optimal rolling characteristics on uneven surfaces and rough pavements.
- Safely overcomes small ledges, cracks in the concrete and countersunk rail tracks.
- Multi-purpose use: Also useable as two single trolleys, each with half of the combined load capacity. No additional accessories needed.
- Custom solutions available: Ask for individual design with specific measurements and adjustable connections.

Available with twistlock via special order.

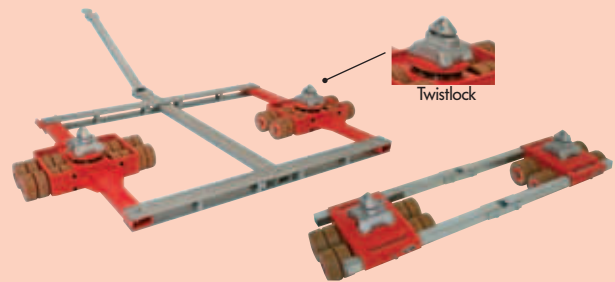

Load weight up to			15 metric tons	30 metric tons
Type	Sketch		JTL 15 G	JTLB 30 G
Load capacity		kg / lbs	15 000 / 33 000	30 000 / 66 100
Number of castors		pcs	16	16
Castor dimensions	Ø x l	mm / in	140 x 59 / 5.5 x 2.3"	140 x 59 / 5.5 x 2.3"
Fitting height		mm / in	180 / 7.1"	180 / 7.1"
Supporting surface of turntable	Ø C	mm / in	170 / 6.7"	215 / 8.5"
Dimensions	L1 x B1	mm / in	1 020 x 440 / 40.2 x 17.3"	1 328 x 740 / 54.3 x 29.1"
Width of track on connection rod	E	mm / in	1 330 / 52.4"	1 700 / 66.9"
Adjustable from-to Vmin. -Vmax.		mm / in	900 - 1 230* / 35.4-48.4"	1 270 - 1 600 / 50 x 63"
Adjustable			3x	3x
Dimensions	L2 x B2	mm / in	1 260 x 1670 / 49.5 x 65.6"	1 620 x 2 340 / 63.8 x 92.1"
Handlebar with pulling eye	Length	mm / in	1 230 / 48.4"	1 230 / 48.4"
Weight JUWathan plus		kg	168 / 370	291 / 642
<b>Order-no. with JUWathan plus</b>			<b>12 150 140-V</b>	<b>12 302 140-V</b>

\*other lengths on request



# Twistlock / „Weld-on Cone“

safety transport of container



**JTLB 14 K**  
with Weld-on Cone



**JFB 14 K**  
with Weld-on Cone

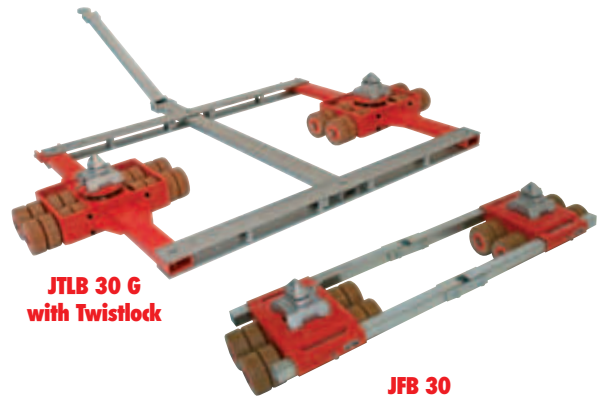

**JTLB 30 G**  
with Twistlock

**JFB 30**  
with Twistlock

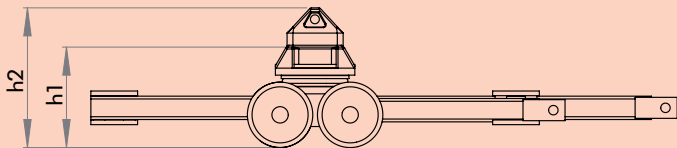

## Advantages in detail

- Container can be transported on a low installation level.
- "Twist lock" or "Weld-on Cone" systems easy to refit also for transport trolleys Series K.
- Suitable for all ISO-container.
- Safer transport of containers
- Containers can be moved with a low fitting height.
- Interlocking fit and force fit between the trolley and the containers (Twistlock) or just interlocking fit (Weld-on Cone System).
- Weld-on Cone easy to upgrade for the Series K and Series K Professional trolleys. Compatible for all ISO-Containers.
- Weld-on Cone version includes 2 modified turntables or cassettes with container adapters, non-lockable, and extended track rods (2.26 m) for ISO containers instead of the standard ones. The tandem trolleys include two steering rods with eyes.
- Lockable Twistlock version includes 2 modified turntables or cassettes with Twistlock-system and extended connecting bars (ISO length: 2.26 m; not adjustable) instead of the standard ones. The tandem trolleys include 2 steering rods with eyes. For longer track rods and connecting rods please refer to accessories on page 31.

### „Weld-on Cone“ system

Please refer to page 18-21, 26 for technical details

Type	JTLB 14 K	JFB 6 K	JFB 7 K	JFB 12 K	JFB 14 K	JFB 9 K	JFB 10 K
Fitting height h1	110	110	110	110	110	110	110
Fitting height h2	180	180	180	180	180	180	180
Order number	12 121 085-W	08 061 085-W	08 071 085-W	08 121 085-W	08 141 085-W	08 091 085-W	08 101 085-W

### Twistlock system

Please refer to page 18-21, 26 for technical details

Type	JTL 15	JTL 30 G	JFB 15	JFB 22	JFB 30
Fitting height h1	215	215	215	215	215
Fitting height h2	330	330	330	330	330
Order number	12 260 140-T	12 302 140-T	10 151 140-T	10 221 140-T	10 302 140-T

# Suitable Accessories

## For trolleys



### 01. Pulling handle extension

clamps onto the standard pulling handle.  
For trolleys on page 18-21 and 22.

Type	Series K	Series K	JL 18 S
Length	500 mm / 19.7" in	1 000 mm / 39.4" in	1 000 mm / 39.4" in
Order number	92 010 060-B	92 010 061-B	92 010 062-B

### 02. Connecting bar extension set

for insertion between the standard connecting bars.  
For trolleys on page 18-21.

Type	Series K
Length	635 mm / 25" in
Order number	92 010 157-B

### 03. Extended connecting bar

for trolleys JFB 6 K up to JFB 14 K.

Type	Series K
Length	per customer request
Order number	92 010 063-B

### 04. Pulling handle with towing eye

for steerable trolleys JLB 3 K on page 19 and JTLB 6 on page 26.

Type	JLB 3 K
Length	1 120 mm / 44.1" in
Order number	92 010 148-B

### 05. Extension tandem bar

for trolleys JTLB 6 K / JTLB 14 K on page 26.

Type	JTLB 6 K	JTLB 14 K
Length	per customer request	per customer request
Order number	92 010 160-B	92 010 161-B

### 06. Pulling handle without towing eye

for revolving trolley **JKB** on page 15-17.

Type	JKB 1	JKB 1,5 - JKB 7,5
Length	1 000 mm / 39.4" in	1 120 mm / 44.1" in
Order number	92 060 082-L	92 030 085-L

### 07. Connecting bar

for revolving trolley **JKB** on page 15-17.

Type	JKB 1	JKB 1,5 / JKB 3	JKB 4 / JKB 6 / JKB 7,5
Length	1 000 mm / 39.4" in	1 200 mm / 47.2" in	2 400 mm / 94.5" in
Order number	92 060 082-V	92 030 085-V	92 040 085-V

### 08. Pulling handle with a removable handle

for Series K trolleys on page 18-21. Available as complete pulling handle or as retrofit kit for existing pulling handles.

Type	Series K	Series K
	pulling handle complete	handle + bolt
Order number	92 010 122-B	92 090 300-B

### 09. „Weld-on Cone“ System

Consisting of two modified turntables and two cassette attachments for Series K trolleys.

Type	JLB 3/6/7	JL 9/10/12/14	JFB 6-14
Order number	92 007 070-B	92 007 140-B	92 008 140-B

### 10. Steering traverse

For easy moving of heavy loads by hand pallet trucks or forklifts.

Type	JLT 3	JLT 15
Load capacity	3 to	15 to
Order number	13 203 000-V	13 215 000-V

# Sturdy castors for any application

High quality coatings



Series K



Series K Professional



Series G



Series S



Series H



Series H

JUWathan® plus

JUWathan®

## Sketch

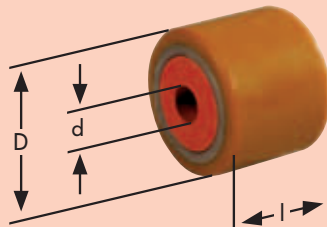

## Recommended use

Recommended use for	Castor type and coat		
	JUWathan® JUWathan® plus JUWathan® Professional	JUWAmid	Steel
Plain and clean floors	✓	✓	
For any floors, swarf resistant	✓		
Bad floors with roughness			✓

## Details

- **JUWathan® castor design:** The coating is molded around a steel core. Two precision ball bearings are pressed into the steel core.
- **JUWathan® plus castor design:** Based on the JUWathan roller, the new JUWathan-plus castor has a new and improved coating material and a more advanced construction. **NEW:** An aluminum core replaces the steel core for easier handling at the same strength. A polyurethane based lining material is bonded around the aluminum core. This construction reduces the rolling resistance and weight by nearly 30 percent.
- **JUWathan® Professional:** The professional series roller was developed based on the JUWathan plus roller. The side-by-side double roller system provides higher load capacity (2x2 ball bearings) and offers greatly reduced rolling resistance. Turning of the steerable trolley requires less force because the rollers can turn against one another resulting in extremely reduced friction between surface and roller. The much lower friction resistance also causes the rollers on the rear axis to follow in a truer course.

JUWathan® plus	Sketch	Series K*	Series K Professional*	Series G*	
Load capacity		kg / lbs	750 / 1 650	875 / 1 925	1 000 / 2 200
Outside diameter	D	mm / in	85 / 3.3"	85 / 3.3"	140 / 5.5"
Inside diameter	d	mm / in	25 / 1"	25 / 1"	35 / 1.4"
Fitting length	l	mm / in	85 / 3.3"	85 / 3.3"	59 / 2.3"
Weight		kg / lbs	0,85 / 1.9	0,95 / 2.1	1,50 / 3.3
<b>Order-no.</b>			<b>95 050 057-V</b>	<b>95 050 089-D</b>	<b>95 050 047-V</b>

JUWathan®	Sketch	Series S*	Series H*	Series H*	
Load capacity		kg / lbs	1 500 / 3 300	2 100 / 4 620	5 000 / 11 000
Outside diameter	D	mm / in	90 / 3.5"	200 / 7.9"	200 / 7.9"
Inside diameter	d	mm / in	35 / 1.4"	70 / 2.8"	70 / 2.8"
Fitting length	l	mm / in	120 / 4.7"	85 / 3.3"	170 / 6.7"
Weight		kg / lbs	1,75 / 3.9	8,5 / 18.7	18 / 39.7
<b>Order-no.</b>			<b>95 050 025-V</b>	<b>95 050 090-V</b>	<b>95 050 053-V</b>

\*We grant 5 years of warranty on operability of our wheels except improper use or normal abrasion.

# Our products are also available in galvanized steel

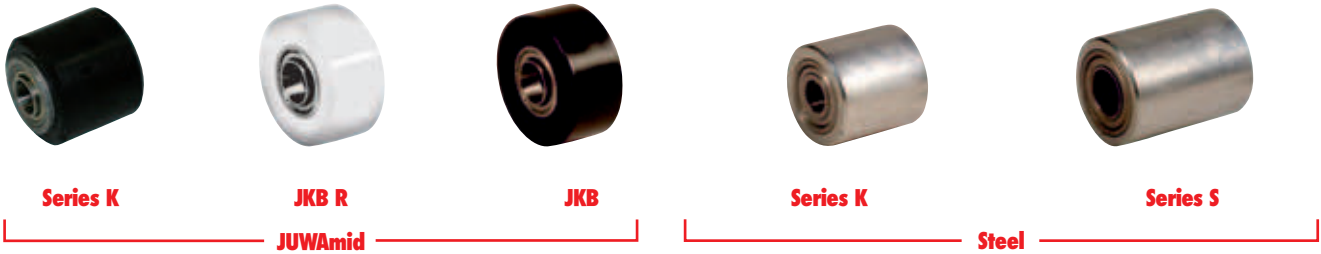

## Details

- **JUWAmid castor design:** The coating is molded around a steel core. Two precision ball bearings are pressed into the steel core.
- **Steel castor design:** The steel body is made of a seamless steel tube. Two ball bearings are pressed into the body.

Sketch

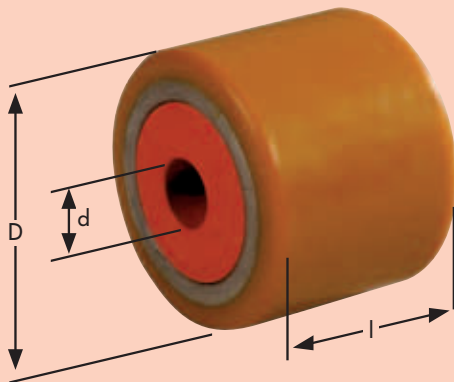

Steel	Sketch		Series K	Series S
Load capacity		kg/lbs	750 / 1 650	1 500 / 3 300
Outside diameter	D	mm/in	85 / 3.3"	90 / 3.5"
Inside diameter	d	mm/in	25 / 1"	35 / 1.4"
Fitting length	l	mm/in	85 / 3.3"	120 / 4.7"
Weight		kg/lbs	2,40 / 5.3	2,85 / 6.3
<b>Order-no.</b>			<b>95 050 043-S</b>	<b>95 050 026-S</b>

JUWAmid	Sketch		JKB	JKB R	Series K
Load capacity		kg/lbs	375 / 825	375 / 825	750 / 1 650
Outside diameter	D	mm/in	85 / 3.3"	85 / 3.3"	85 / 3.3"
Inside diameter	d	mm/in	25 / 1"	25 / 1"	25 / 1"
Fitting length	l	mm/in	43 / 1.7"	43 / 1.7"	85 / 3.3"
Weight		kg/lbs	0,3 / 0.7	0,3 / 0.7	1 / 2
<b>Order-no.</b>			<b>95 050 088-P</b>	<b>95 050 091-P</b>	<b>95 050 023-P</b>