

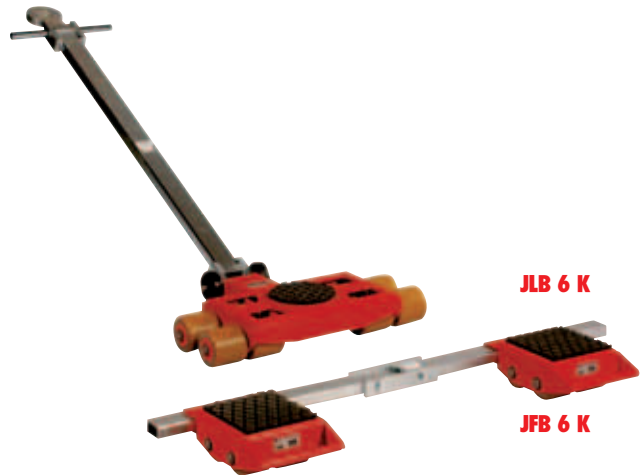

Transport trolleys Series K

For loads up to 24 metric tons



Available with:

JUWathan® plus coated aluminium castor  for any floors Order no. 95 050 057-V	JUWamid coated aluminium castor  for clean floors Order no. 95 050 023-P	Steel castor  for not sensitive floors Order no. 95 050 043-S
---	--	---

Please refer to page 32-33 for additional roller information



Castors with ball bearings guarantee easy movement

Example for load distribution on 12 tons trolley combination:

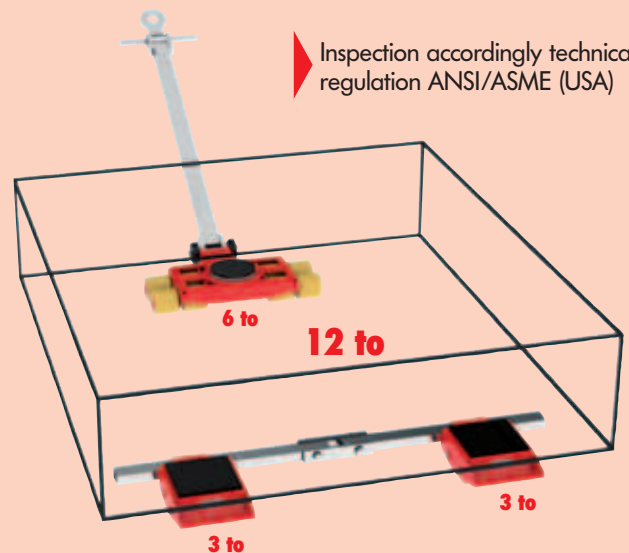

Load weight up to

Type	Sketch	6 metric tons		12 metric tons		
		JLB 3 K	JFB 3 K	JLB 6 K	JFB 6 K	
Load capacity	kg/lbs	3 000 / 6 600	3 000 / 6 600	6 000 / 13 200	6 000 / 13 200	
Number of castors	pcs	4	4	8	8	
Castors dimensions	Ø x l	mm/in	85 x 85 / 3.3 x 3.3"	85 x 85 / 3.3 x 3.3"	85 x 85 / 3.3 x 3.3"	85 x 85 / 3.3 x 3.3"
Fitting height	mm/in	110 / 4.3"	110 / 4.3"	110 / 4.3"	110 / 4.3"	
Supporting surface per cassette	E x F	mm/in	120 x 80 / 4.7 x 3.1"		175 x 170 / 6.9 x 6.7"	
Cassette dimensions	L x B x H	mm/in	190 x 125 / 7.5 x 4.9"		325 x 200 / 12.8 x 7.9"	
Connecting rod with joint	Length	mm/in		1 000**/39.4"	1 230 / 48.4"	
Cassettes adjustable from - to	G - H	mm/in	125 - 880 / 4.9 - 34.6"		400 - 1 030 / 15.7 - 40.6"	
Supporting surface of turnable	Ø C	mm/in	150 / 5.9"		150 / 5.9"	
Dimensions	L x B x H	mm/in	225 x 280 / 8.9 x 11"		445 x 590 / 17.5 x 23.2"	
Handlebar with pulling eye	Length	mm/in	990* / 39"		1 120 / 44.1"	
Weight JUWathan plus	kg/lbs	12 / 26	11 / 24	33 / 72	25 / 55	
Order number with JUWathan plus		07 031 085-V	08 031 085-V	07 061 085-V	08 061 085-V	

*JLB 3 K steering bar without pulling eye — **JFB 3 K without joint

Transport trolleys Series K

For loads up to 24 metric tons



Sketch

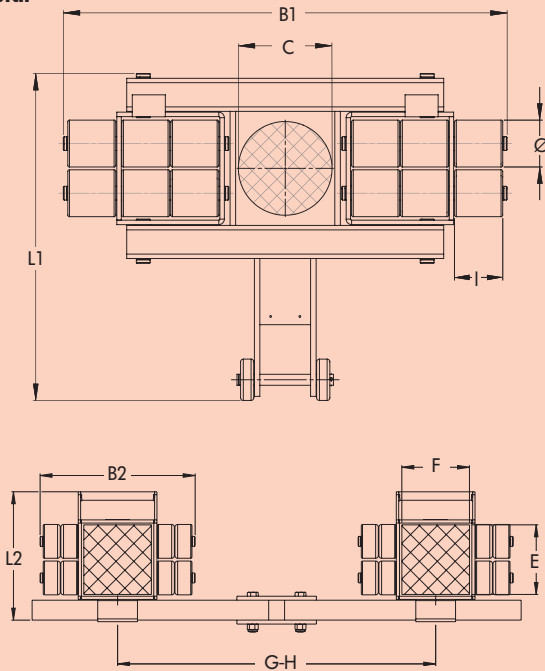

Advantages in detail

- Galvanized axles and safety clip rings for improved protection against corrosion.
- Outfitted with highest quality rollers as standard.
- Reduced weight through advanced construction of load cassettes.
- All transport trolleys are ready for use: The steerable transport trolley is fitted with a ball bearing supported turntable and a handlebar (as shown in picture). The adjustable-width transport trolley consists of two transport units and connecting rod.
- The Series K handle bars are now also available with a removable handle. (See on page 31).



▶ Inspection accordingly technical regulation ANSI/ASME (USA)

Load weight up to		18 metric tons		24 metric tons	
Type	Sketch	JL 9 K	JFB 9 K	JL 12 K	JFB 12 K
Load capacity	kg / lbs	9 000 / 19 800	9 000 / 19 800	12 000 / 26 400	12 000 / 26 400
Number of castors	pcs	12	12	16	16
Castors dimensions	Ø x l mm / in	85 x 85 / 3.3 x 3.3"	85 x 85 / 3.3 x 3.3"	85 x 85 / 3.3 x 3.3"	85 x 85 / 3.3 x 3.3"
Fitting height	mm / in	110 / 4.3"	110 / 4.3"	110 / 4.3"	110 / 4.3"
Supporting surface per cassette	E x F mm / in		175 x 170 / 6.9 x 6.7		175 x 170 / 6.9 x 6.7
Cassette dimensions	L 2 x B 2 mm / in		325 x 390 / 12.8 x 15.4		325 x 390 / 12.8 x 15.4
Connecting rod with joint	Length mm / in		1 230 / 48.4"		1 230 / 48.4"
Cassettes adjustable from - to	G - H mm / in		400 - 1 030 / 15.7 - 40.6"		400 - 1 030 / 15.7 - 40.6"
Supporting surface of turntable	Ø C mm / in	170 / 6.7"		170 / 6.7"	
Dimensions	L 1 x B 1 mm / in	580 x 820 / 22.8 x 32.3"		580 x 1000 / 22.8 x 39.3"	
Handlebar with pulling eye	Length mm / in	1 120 / 44.1"		1 120 / 44.1"	
Weight JUWAtan plus	kg / lbs	54 / 119	32 / 70	64 / 141	35 / 77
Order number with JUWAtan plus		07 090 085-V	08 091 085-V	07 120 085-V	08 121 085-V



Transport trolleys Series K professional

For load weights up to 28 metric tons



Available with:

Professional castor
JUWAthan® plus coated aluminium castor

for any floors
Order number 95 050 089-D

▶ Please refer to page 32-33 for additional roller information.

Example for load distribution on 14 tons trolley combination:

▶ Inspection accordingly technical regulation ANSI/ASME (USA)

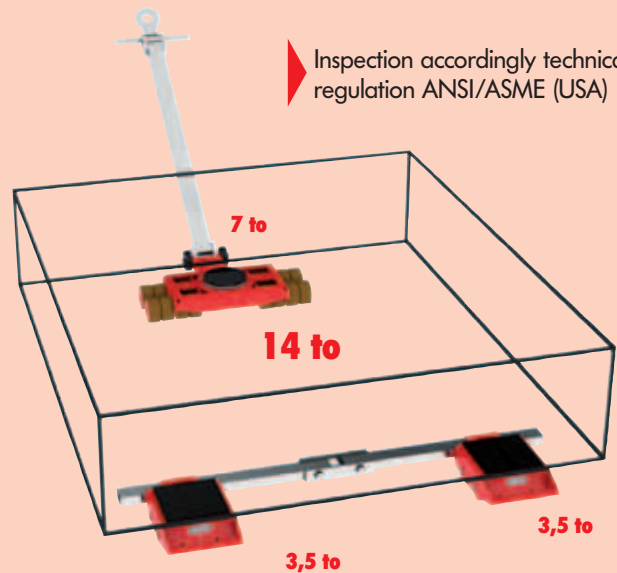

Castors with ball bearings guarantee easy motion

Type	Sketch	14 metric tons		20 metric tons	
		JLB 7 K	JFB 7 K	JL 10 K	JFB 10 K
Load capacity	kg / lbs	7 000 / 15 400	7 000 / 15 400	10 000 / 22 000	10 000 / 22 000
Number of castors	pcs	8	8	12	12
Castors dimensions	Ø x l mm / in	85 x 85 / 3.3 x 3.3"	85 x 85 / 3.3 x 3.3"	85 x 85 / 3.3 x 3.3"	85 x 85 / 3.3 x 3.3"
Fitting height	mm / in	110 / 4.3"	110 / 4.3"	110 / 4.3"	110 / 4.3"
Supporting surface per cassette	E x F mm / in		175 x 170 / 6.9 x 6.7"		175 x 170 / 6.9 x 6.7"
Cassette dimensions	L x B x H mm / in		325 x 200 / 12.8 x 7.9"		325 x 390 / 12.8 x 15.4"
Connecting rod with joint	Length mm / in		1 230 / 48.4"		1 230 / 48.4"
Cassettes adjustable from - to	G - H mm / in		400 - 1 030 / 15.7 - 40.6"		400 - 1 030 / 15.7 - 40.6"
Supporting surface of turnable	Ø C mm / in	150 / 5.9"		170 / 6.7"	
Dimensions	L x B x H mm / in	445 x 590 / 17.5 x 23.2"		580 x 820 / 22.8 x 32.3"	
Handlebar with pulling eye	Length mm / in	1 120 / 44.1"		1 120 / 44.1"	
Weight professional	kg / lbs	36 / 79	27 / 59	56 / 123	35 / 77
Order-no. with professional		07 071 085-D	08 071 085-D	07 100 085-D	08 101 085-D

Transport trolleys Series K professional

For load weights up to 28 metric tons

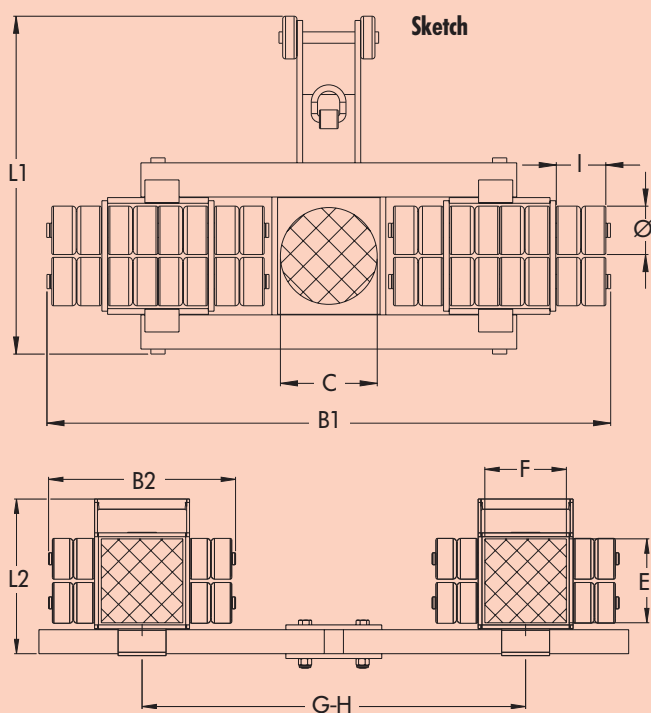

Advantages in detail

- Galvanized axles and safety clip rings for improved protection against corrosion.
- The double roller design results in dramatically easier steering due to reduced friction forces in curves. The much lower friction resistance also causes the rollers on the rear axis to follow in a truer course.
- Higher capacity at same dimension as Series K trolleys.
- All transport trolleys are ready for use: Steerable transport trolley includes ball bearing supported turntable and a handlebar, the adjustable-width transport trolley consists of two load cassettes and connecting rod.
- The Series K handle bars are now also available with a removable handle. (See on page 31).

Removable handle



▶ Inspection accordingly technical regulation ANSI/ASME (USA)

Load weight up to

28 metric tons

Type	Sketch		JL 14 K	JFB 14 K
Load capacity		kg / lbs	14 000 / 30 800	14 000 / 30 800
Number of castors		pcs	16	16
Castor dimensions	$\emptyset \times l$	mm / in	85 x 85 / 3.3 x 3.3"	85 x 85 / 3.3 x 3.3"
Fitting height		mm / in	110 / 4.3"	110 / 4.3"
Supporting surface per cassette	E x F	mm / in		175 x 170 / 6.9 x 6.7
Cassette dimensions	L2 x B2	mm / in		325 x 390 / 12.8 x 15.4
Connecting rod with joint	Length	mm / in		1 230 / 48.4"
Cassettes adjustable from - to	G - H	mm / in		400 - 1 030 / 15.7 - 40.6"
Supporting surface of turntable	$\emptyset C$	mm / in	170 / 6.7"	
Dimensions	L1 x B1	mm / in	580 x 100 / 22.8 x 39,3"	
Handlebar with pulling eye	Length	mm / in	1 120 / 44.1"	
Weight professional		kg / lbs	68 / 150	39 / 86
Order-no. with professional			07 140 085-D	08 141 085-D



Transport trolleys Series S

For load weights up to 48 metric tons

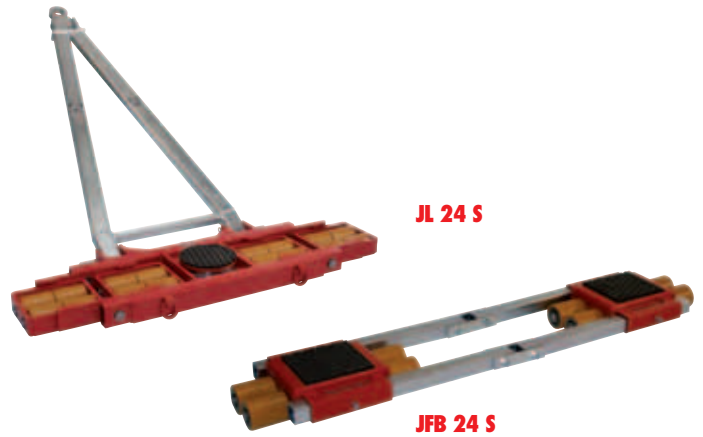
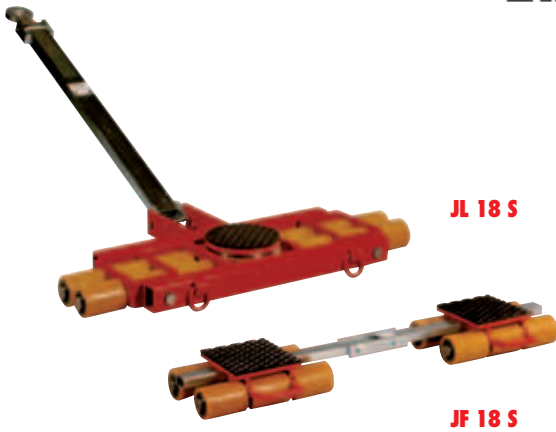

Available with:
JUWATHan-coated steel castors



for any floors
Order number 95 050 025-V

Available with:
Steel castors



for insensitve floors
Order number 95 050 026-S

Advantages in detail

- Pivoting roller cassettes within the frame assure even pressure distribution across all rollers and across the floor. No need for complex and expensive hydraulic compensation system.
- Low height at only 125 mm / 4.9" with high capacity.

▶ Please refer to page 32-33 for additional roller information

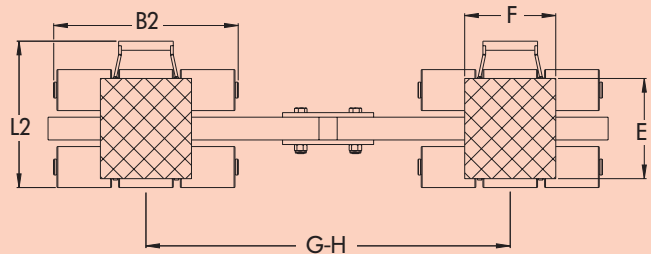
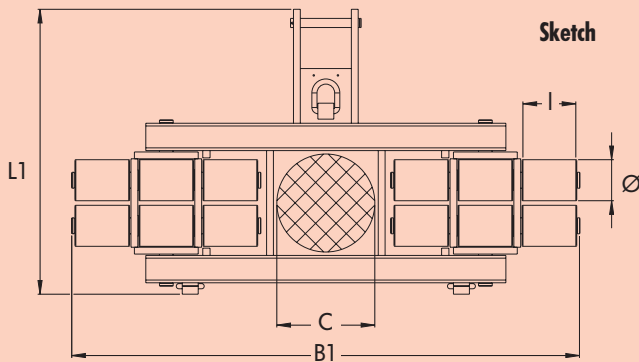

Type	Sketch	36 metric tons		48 metric tons	
		JL 18 S	JF 18 S	JL 24 S	JFB 24 S
Load capacity	kg / lbs	18 000 / 39 600	18 000 / 39 600	24 000 / 52 800	24 000 / 52 800
Number of castors	pcs	12	12	16	16
Castor dimensions	Ø x l mm / in	90 x 120 / 3.5 x 4.7"	90 x 120 / 3.5 x 4.7"	90 x 120 / 3.5 x 4.7"	90 x 120 / 3.5 x 4.7"
Fitting height	mm / in	125 / 4.9"	125 / 4.9"	125 / 4.9"	125 / 4.9"
Supporting surface per cassette	E x F mm / in		220 x 200 / 8.6 x 7.8"		200 x 220 / 7.9 x 8.7"
Cassette dimensions	L2 x B2 mm / in		260 x 410 / 10.2 x 16.1"		370 x 565 / 14.6 x 22.2"
Connecting rod with joint	Length mm / in		1 230 / 48.4"		2 x 1 540 / 60.6"
Cassettes adjustable from - to	G - H mm / in		420 - 1100 / 16.5 - 43.3"		700 - 1300 / 27.6 - 51.2"
Supporting surface of turntable	Ø C mm / in		215 / 8.5"		215 / 8.5"
Dimensions	L1 x B1 mm / in		600 x 1 120 / 23.6 x 44.1"		610 x 1 500 / 24 x 59"
Handlebar with pulling eye	mm / in		1 230 / 48.4"		1 590 / 62.6"
Weight JUWATHan Steel	kg - lbs		110 / 118 - 242 / 260		205 / 224 - 452 / 494
Order-no. with JUWATHan coated castors			05 180 090-V	06 180 090-V	05 240 090-V 06 241 090-V
Order-no. with steel castors			05 180 090-S	06 180 090-S	05 240 090-S 06 241 090-S



Self-powered trolley

**Load capacity 15 metric tons,
Pulling capacity 30 metric tons**



JLA 15/30 G



JLA Set 1



JLA Set 2



JLA Set 3



Sketch JLA 15/30 G

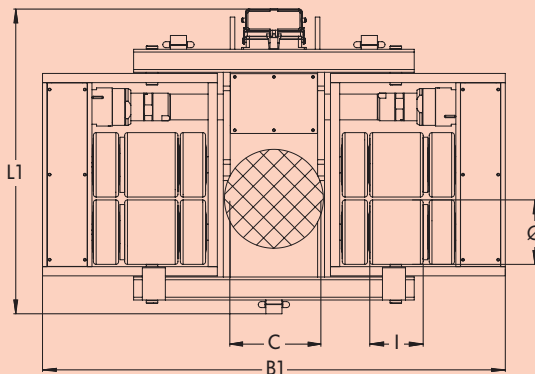

Higher loading capacities on request.

Advantages in detail



- Easy set-up. Connect pneumatic hose and go.
- No need for separate pulling vehicle.
- Similar dimensions as dollies in the same series.
- Low maintenance.
- All hoses are detachable creating compact system for easy transport.
- Capable of turning 360°.
- No need for electric power cable.
- Standard pneumatic connection with 116 psi and a volume of air with 1500 l / min is required.
- Also usable in Ex-areas and in corrosive atmosphere.
- Continuously variable through regulation of working pressure.

JLA Sets

Type	JLA Set 1	JLA Set 2	JLA Set 3
JLA incl. steering unit	1 x	1 x	1 x
hose length/diameter	30 m / 8 mm 1181" / 0,31"	30 m / 19 mm 1181" / 0,75"	30 m / 19 mm 1181" / 0,75"
Cart + oil + chain spray	1 x	1 x	1 x
JFB 15 G	-	-	1 x
Order number	22 150 140-VP1	22 150 140-VP2	22 150 140-VP3

Type	Sketch	JLA 15/30 G
Load capacity	kg / lbs	15.000 / 33.000
Pulling capacity	kg / lbs	30.000 / 66.000
Number of castors	pcs	4 G / 8 G 1/2
Castor dimensions	Ø x l	mm / in
Fitting height	mm / in	180 / 7.1"
Supporting surface of turntable	Ø C	mm / in
Dimensions	L1 x B1	mm / in
Weight	kg / lbs	175 / 385
Air consumption	L / sec.	25
Order-no. with JUWathan plus		22 150 140-V

Transport trolleys Series G professional

For load weights up to 60 metric tons



JLB 15 G

JFB 15 G



JLB 22 G

JFB 22 G

Available with:

JUWathan® plus-coated aluminium core



for any floors

Order number 95 050 047-V

▶ Please refer to page 32-33 for additional roller information.

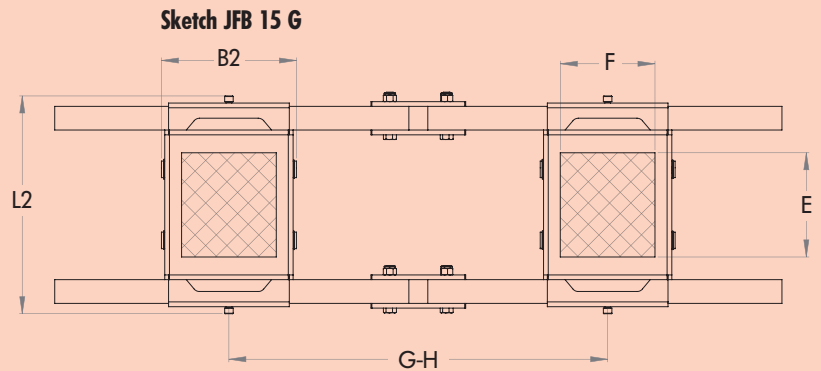
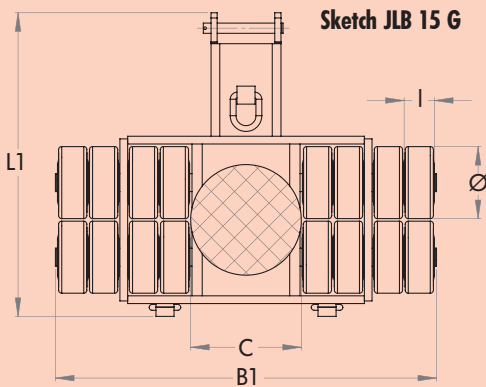

Type	Sketch	30 metric tons		45 metric tons	
		JLB 15 G	JFB 15 G	JLB 22 G	JFB 22 G
Load capacity	kg / lbs	15 000 / 33 000	15 000 / 33 000	22 500 / 49 500	22 500 / 49 500
Number of castors	pcs	16	16	24	24
Castor dimensions	Ø x l	mm / in	140 x 59 / 5.5 x 2.3"	140 x 59 / 5.5 x 2.3"	140 x 59 / 5.5 x 2.3"
Fitting height	mm / in	180 / 7.1"	180 / 7.1"	180 / 7.1"	180 / 7.1"
Supporting surface per cassette	E x F	mm / in	220 x 200 / 8.6 x 7.8"	220 x 200 / 8.6 x 7.8"	220 x 200 / 8.6 x 7.8"
Cassette dimensions	L2 x B2	mm / in	460 x 285 / 18.0 x 11.1"	460 x 400 / 18.0 x 20.6"	460 x 400 / 18.0 x 20.6"
Connecting rod with joint	Length	mm / in	2 x 1 540 / 60.6"	2 x 1 540 / 60.6"	2 x 1 540 / 60.6"
Cassettes adjustable from - to	G - H	mm / in	475 - 1 300 / 18.7 - 54.3"	530 - 1 300 / 20.7 - 54.3"	530 - 1 300 / 20.7 - 54.3"
Supporting surface of turnable	Ø C	mm / in	215 / 8.5"	215 / 8.5"	215 / 8.5"
Dimensions	L1 x B1	mm / in	565 x 741 / 22.2 x 29.1"	565 x 981 / 22.2 x 38.6"	565 x 981 / 22.2 x 38.6"
Handlebar with pulling eye	Length	mm / in	1 230 / 48.4"	1 450 / 57"	1 450 / 57"
Weight JUWathan plus	kg / lbs	96 / 212	88 / 194	129 / 284	113 / 249
Order-no. with JUWathan plus		09 151 140-V	10 151 140-V	09 221 140-V	10 221 140-V

Transport trolleys Series G professional

For load weights up to 60 metric tons

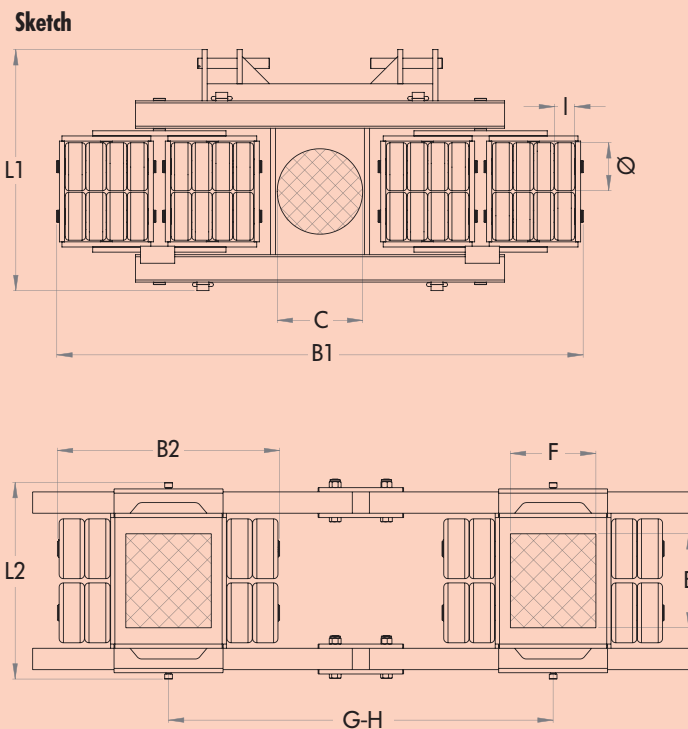
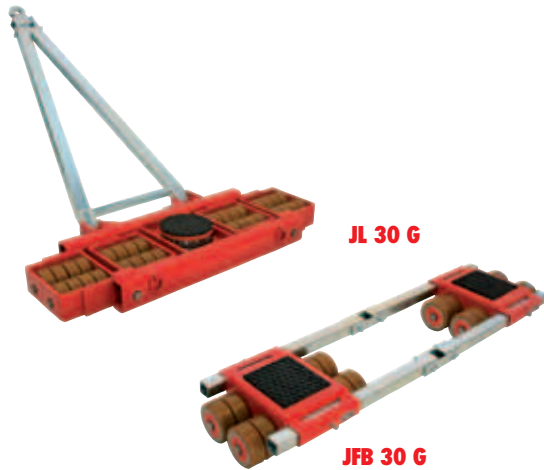

Advantages in detail

- Pivoting roller cassettes within the frame assure even pressure distribution across all rollers and across the floor. No need for complex and expensive hydraulic compensation system.
- The double roller design results in dramatically easier steering due to reduced friction forces in curves. The much lower friction resistance also causes the rollers on the rear axis to follow in a truer course.
- All transport trolleys are ready for use: The steerable transport trolley is fitted with a ball bearing supported turntable and a handlebar (as shown in picture). The adjustable-width transport trolley consists of two transport units and connecting rod.

Load weight up to

60 metric tons

Type	Sketch	JL 30 G	JFB 30 G
Load capacity	kg / lbs	30 000 / 66 100	30 000 / 66 100
Number of castors	pcs	32	32
Castor dimensions	Ø x l mm / in	140 x 59 / 5.5 x 2.3"	140 x 59 / 5.5 x 2.3"
Fitting height	mm / in	180 / 7.1"	180 / 7.1"
Supporting surface per cassette	E x F mm / in		220 x 200 / 8.6 x 7.8"
Cassette dimensions	L2 x B2 mm / in		460 x 528 / 18.0 x 20.6"
Connecting rod with joint	Length mm / in		2 x 1 540 / 60.6"
Cassettes adjustable from - to	G - H mm / in		530 - 1 300 / 20.7 - 54.3"
Supporting surface of turntable	Ø C mm / in	250 / 9.4"	
Dimensions	L1 x B1 mm / in	750 x 1 550 / 29.5 x 61"	
Handlebar with pulling eye	Length mm / in	1 590 / 62.6"	
Weight JUWathan plus	kg	312 / 688	126 / 278
Order-no. with JUWathan plus		09 301 140-V	10 302 140-V

*other lengths on request



Transport trolleys Series K professional

For load weights up to 12 metric tons



JTLB 6 K

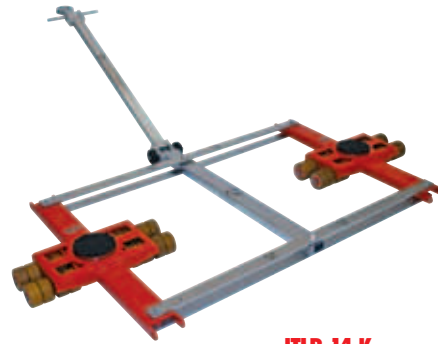

JTLB 14 K

Available with:

Professional castor
JUWAthan® plus coated aluminium castor



for any floors
Order number 95 050 089-D

▶ Please refer to page 32-33 for additional roller information

Advantages in detail

- Galvanized axles and safety clip rings for improved protection against corrosion.
- The double roller design results in dramatically easier steering due to reduced friction forces in curves. The much lower friction resistance also causes the rollers on the rear axis to following in a truer course.
- Tandem transport trolley for loads with no leading or trailing edge centre support.
- Ready for use: 2 interconnected steerable trolleys with 2 handlebars and two tandem connecting rods.
- Multi-purpose use: Also useable as two single trolleys, each with half of the combined load capacity. No additional accessories needed.

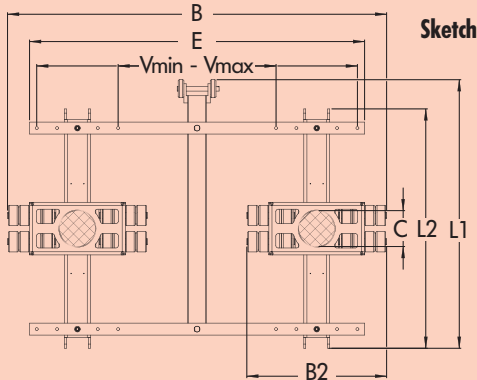

For short radius curves

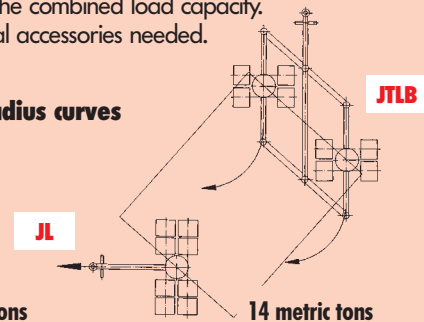

Load weight up to

Type	Sketch		JTLB 6 K	JTLB 14 K
Load capacity		kg / lbs	6 000 / 13 200	14 000 / 30 800
Number of castors		pcs	8	16
Castor dimensions	Ø x l	mm / in	85 x 85 / 3.3 x 3.3"	85 x 85 / 3.3 x 3.3"
Fitting height		mm / in	110 / 4.3"	110 / 4.3"
Cassette dimensions	L2 x B2	mm / in	600 x 280 / 23.6 x 11"	1 000 x 590 / 39.4 x 23.2"
Supporting surface per cassette	Ø C	mm / in	150 / 5.9"	150 / 5.9"
Connecting rod	E	mm / in	1 000 / 39.4"	1 400 / 55.1"
Adjustable from - to Vmin - Vmax.		mm / in	560 - 960* / 22 - 37.3**	600 - 1 340* / 25.9 - 52.7**
Adjustable			5 x	5 x
Total length width	L1 x B1	mm / in	760 x 1 240 / 29.9 x 48.8"	1 070 x 1 580 / 42.1 x 62.1"
Handlebar with pulling eye	Length	mm / in	990** / 39**	1 120 / 44.1"
Weight professional		kg / lbs	37 / 82	104 / 229
Order-no. with professional			12 061 085-D	12 121 085-D

*other lengths on request **without pulling eye

Transport trolleys Series G professional

For load weights up to 30 metric tons

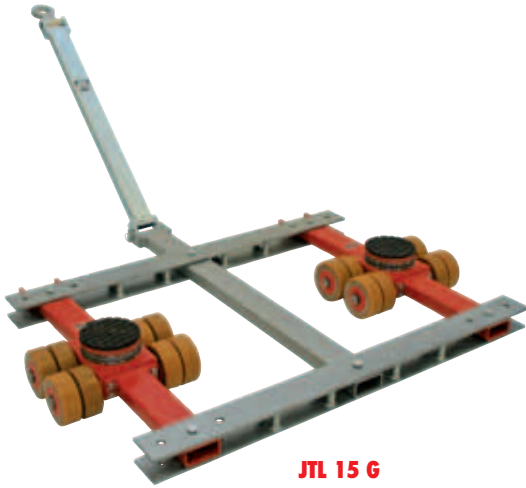

JTL 15 G



JTLB 30 G

Available with:

JUWathan® plus-coated aluminium core



for any floors
Order number 95 050 048-V

▶ Please refer to page 32-33 for additional roller information

Sketch

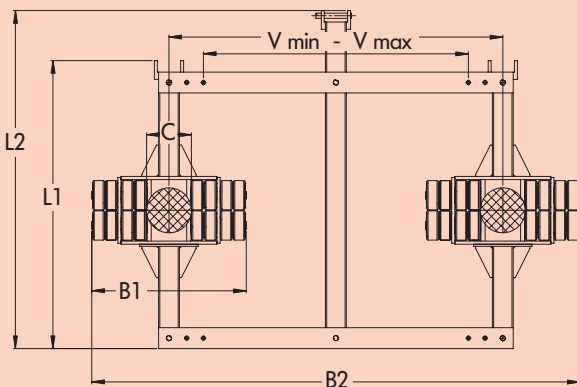

Advantages in detail

- Large rollers warrant optimal rolling characteristics on uneven surfaces and rough pavements.
- Safely overcomes small ledges, cracks in the concrete and countersunk rail tracks.
- Multi-purpose use: Also useable as two single trolleys, each with half of the combined load capacity. No additional accessories needed.
- Custom solutions available: Ask for individual design with specific measurements and adjustable connections.

Available with twistlock via special order.

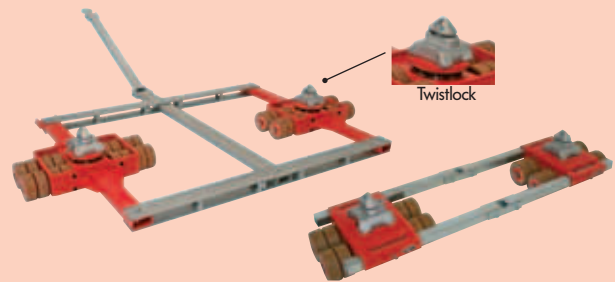

Load weight up to			15 metric tons	30 metric tons
Type	Sketch		JTL 15 G	JTLB 30 G
Load capacity		kg / lbs	15 000 / 33 000	30 000 / 66 100
Number of castors		pcs	16	16
Castor dimensions	Ø x l	mm / in	140 x 59 / 5.5 x 2.3"	140 x 59 / 5.5 x 2.3"
Fitting height		mm / in	180 / 7.1"	180 / 7.1"
Supporting surface of turntable	Ø C	mm / in	170 / 6.7"	215 / 8.5"
Dimensions	L1 x B1	mm / in	1 020 x 440 / 40.2 x 17.3"	1 328 x 740 / 54.3 x 29.1"
Width of track on connection rod	E	mm / in	1 330 / 52.4"	1 700 / 66.9"
Adjustable from-to Vmin. -Vmax.		mm / in	900 - 1 230* / 35.4-48.4"	1 270 - 1 600 / 50 x 63"
Adjustable			3x	3x
Dimensions	L2 x B2	mm / in	1 260 x 1670 / 49.5 x 65.6"	1 620 x 2 340 / 63.8 x 92.1"
Handlebar with pulling eye	Length	mm / in	1 230 / 48.4"	1 230 / 48.4"
Weight JUWathan plus		kg	168 / 370	291 / 642
Order-no. with JUWathan plus			12 150 140-V	12 302 140-V

*other lengths on request



Trolleys Series H

Load capacity up to 120 metric tons



JLB 40 H

JFB 40 H

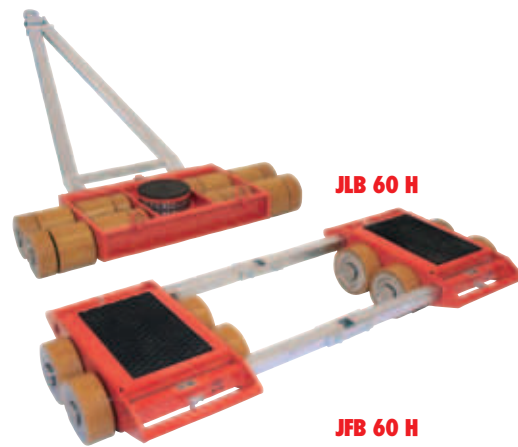

JLB 60 H

JFB 60 H

Available with:
JUWATHan-coated steel castors



for any floors
Order number 95 050 053-V

Available with:
JUWATHan-coated steel castors



for any floors
Order number 95 050 090-V



Please refer to page 32-33 for additional roller information

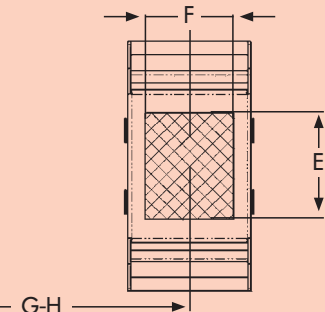
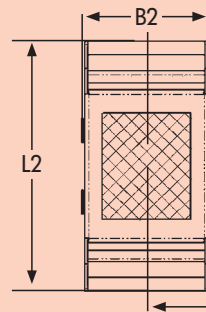
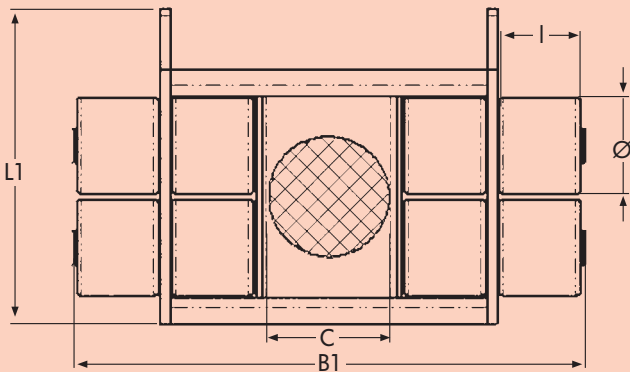

Load weight up to

80 metric tons

120 metric tons

Type	Sketch		JLB 40 H	JFB 40 H	JLB 60 H	JFB 60 H
Load capacity		kg / lbs	40 000 / 88 000	40 000 / 88 000	60 000 / 132 000	60 000 / 132 000
Number of castors		pcs	8	8	8 / 8	8 / 8
Castors dimensions	Ø x l	mm / in	200 x 170 / 7.9 x 6.7"	200 x 170 / 7.9 x 6.7"	200 x 170 / 85 / 79 x 67 / 33"	200 x 170 / 85 / 79 x 67 / 33"
Fitting height		mm / in	230 / 9.1"	230 / 9.1"	230 / 9.1"	230 / 9.1"
Supporting surface per cassette	E x F	mm / in		395 x 260 / 15.6 x 10.2"		395 x 260 / 15.6 x 10.2"
Cassette dimensions	L2 x B2	mm / in		740 x 395 / 29.1 x 15.6"		740 x 580 / 29.1 x 22.8"
Connecting rod with joint	Length	mm / in		2x 1 540 / 60.6"		2x 1 540 / 60.6"
Cassettes adjustable from - to	G - H	mm / in		585 - 1 155 / 23 - 45.5"		700 - 2 800 / 27.6 - 110.2"
Supporting surface of turnable	Ø C	mm / in	250 / 9.8"		250 / 9.8"	
Dimensions	L1 x B1	mm / in	650 x 1 060 / 25.6 x 41.7"		650 x 1 400 / 25.6 x 55.1"	
Handlebar with pulling eye	Length	mm / in	1 590 / 62.6"		1 590 / 62.6"	
Weight JUWATHan plus		kg / lbs	320 / 705	289 / 637	450 / 992	410 / 904
Order-no. with JUWATHan			09 400 200-H	10 400 200-H	09 600 200-H	10 600 200-H
Order-no. with JUWATHan Professional			09 400 205-H	10 400 205-H	09 600 205-H	10 600 205-H

Trolleys Series H

Load capacity up to 160 metric tons



JL 80 H

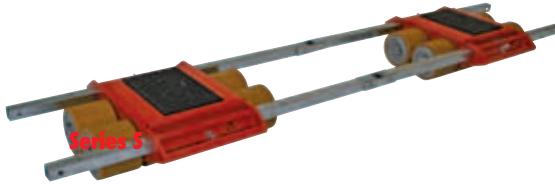

JFB 80 H

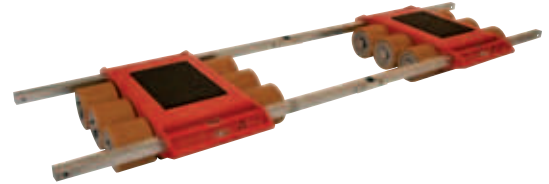

JFB 120 H

Sketch JL 80 H

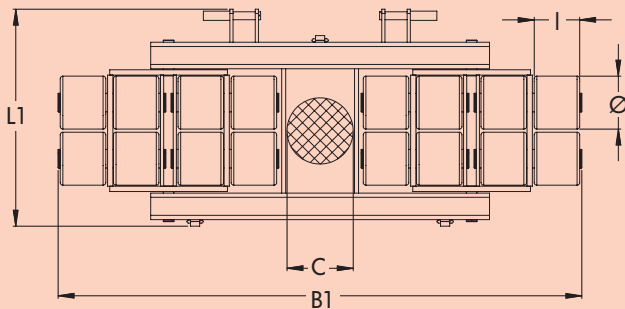

Sketch JFB 80 H

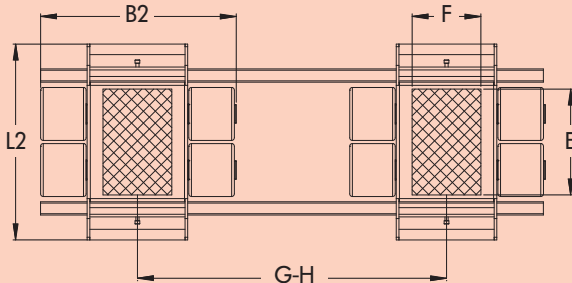

Sketch JFB 120 H

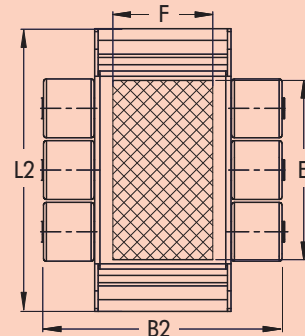

Advantages in detail

- Outfitted with highest quality rollers as standard.
- Unrivalled: Small and lightweight trolleys at super high capacity.
- Reduced weight through advanced construction of frames.
- All transport trolleys are ready for use: The steerable transport trolley is fitted with a ball bearing supported turntable and a handlebar (as shown in picture). The adjustable-width transport trolley consists of two transport units and connecting rods.

Load weight up to

160 metric tons

120 metric tons

Type	Sketch		JL 80 H	JFB 80 H	JFB 120 H
Load capacity		kg / lbs	80 000 / 176 000	80 000 / 176 000	120 000 / 265 000
Number of castors		pcs	16	16	24
Castors dimensions	Ø x l	mm / in	200 x 170 / 7.9 x 6.7"	200 x 170 / 7.9 x 6.7"	200 x 170 / 7.9 x 6.7"
Fitting height		mm / in	240 / 9.4"	240 / 9.4"	240 / 9.4"
Supporting surface per cassette	E x F	mm / in		400 x 260 / 15.7 x 10.2"	440 x 300 / 17.3 x 11.8"
Cassette dimensions	L2 x B2	mm / in		750 x 820 / 29.5 x 32.2"	960 x 830 / 37.7 x 32.6"
Connecting rod with joint	Length	mm / in		2 x 3 000 / 118"	2 x 3 000 / 118"
Cassettes adjustable from - to	G - H	mm / in		1 630 - 3 380 / 64.1-132.9"	1 630 - 3 380 / 64.1-132.9"
Supporting surface of turntable	Ø C	mm / in	250 / 9.8"		
Dimensions	L1 x B1	mm / in	820 x 1 900 / 32.2 x 74.7"		
Handlebar with pulling eye	Length	mm / in	1 590 / 62.6"		
Weight JUWAtan plus		kg / lbs	723 / 1 594	565 / 1 246	815 / 1 797
Order-no. with JUWAtan			09 800 200-H	10 800 200-H	10 912 200-H
Order-no. with JUWAtan Professional			09 800 205-H	10 800 205-H	10 912 205-H



Twistlock / „Weld-on Cone“

safety transport of container

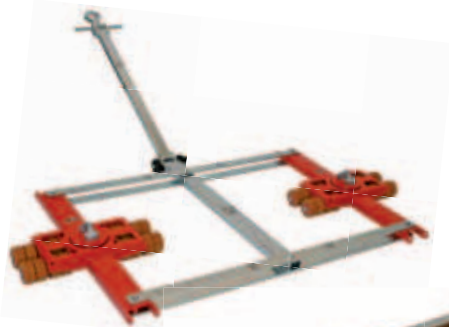

JTLB 14 K
with Weld-on Cone



JFB 14 K
with Weld-on Cone

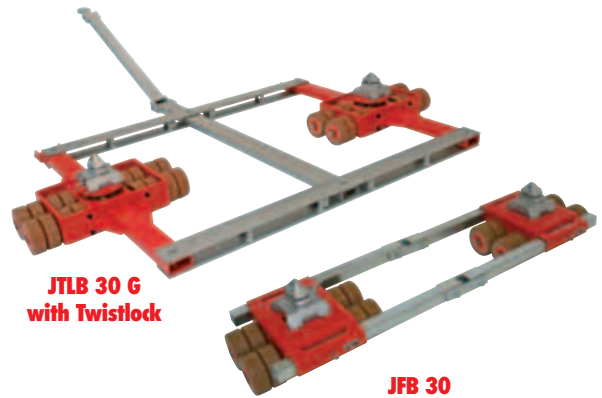

JTLB 30 G
with Twistlock

JFB 30
with Twistlock

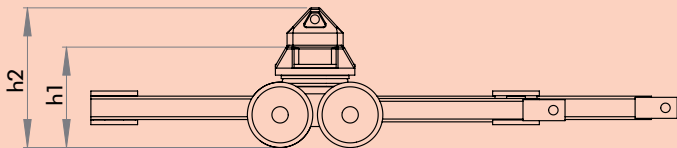

Advantages in detail

- Container can be transported on a low installation level.
- "Twist lock" or "Weld-on Cone" systems easy to refit also for transport trolleys Series K.
- Suitable for all ISO-container.
- Safer transport of containers
- Containers can be moved with a low fitting height.
- Interlocking fit and force fit between the trolley and the containers (Twistlock) or just interlocking fit (Weld-on Cone System).
- Weld-on Cone easy to upgrade for the Series K and Series K Professional trolleys. Compatible for all ISO-Containers.
- Weld-on Cone version includes 2 modified turntables or cassettes with container adapters, non-lockable, and extended track rods (2.26 m) for ISO containers instead of the standard ones. The tandem trolleys include two steering rods with eyes.
- Lockable Twistlock version includes 2 modified turntables or cassettes with Twistlock-system and extended connecting bars (ISO length: 2.26 m; not adjustable) instead of the standard ones. The tandem trolleys include 2 steering rods with eyes. For longer track rods and connecting rods please refer to accessories on page 31.

„Weld-on Cone“ system

Please refer to page 18-21, 26 for technical details

Type	JTLB 14 K	JFB 6 K	JFB 7 K	JFB 12 K	JFB 14 K	JFB 9 K	JFB 10 K
Fitting height h1	110	110	110	110	110	110	110
Fitting height h2	180	180	180	180	180	180	180
Order number	12 121 085-W	08 061 085-W	08 071 085-W	08 121 085-W	08 141 085-W	08 091 085-W	08 101 085-W

Twistlock system

Please refer to page 18-21, 26 for technical details

Type	JTL 15	JTL 30 G	JFB 15	JFB 22	JFB 30
Fitting height h1	215	215	215	215	215
Fitting height h2	330	330	330	330	330
Order number	12 260 140-T	12 302 140-T	10 151 140-T	10 221 140-T	10 302 140-T

Suitable Accessories

For trolleys

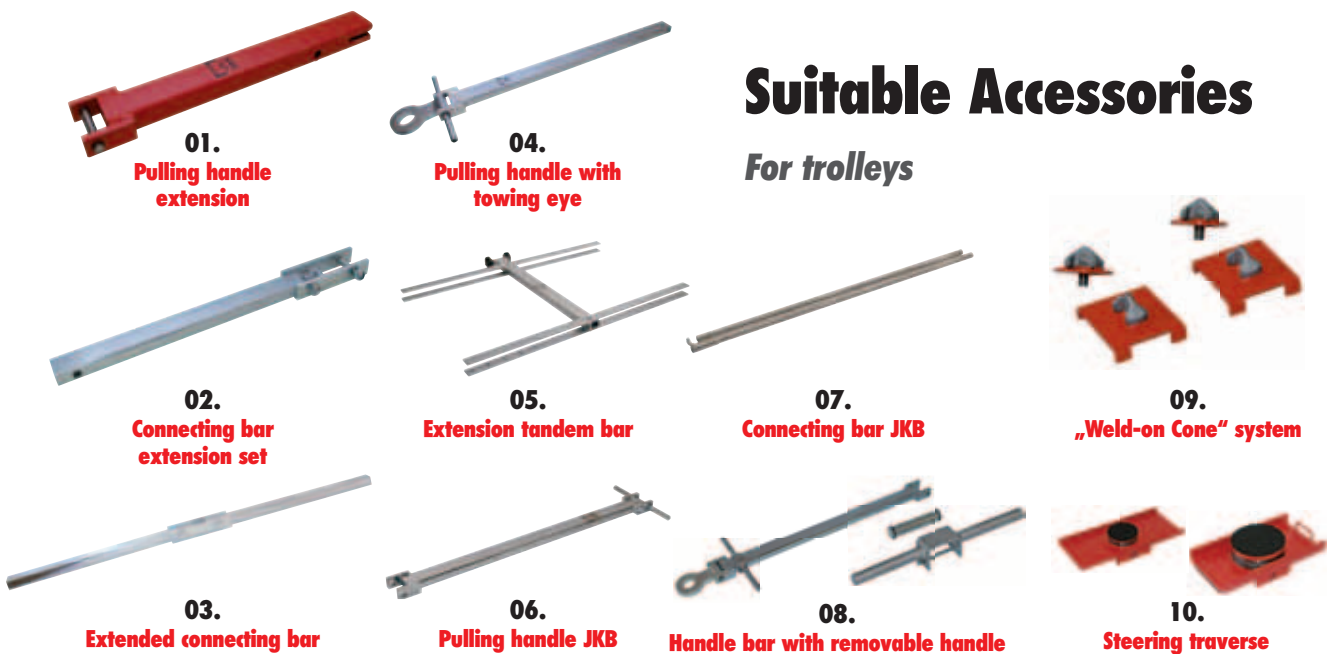

01. Pulling handle extension

clamps onto the standard pulling handle.
For trolleys on page 18-21 and 22.

Type	Series K	Series K	JL 18 S
Length	500 mm / 19.7" in	1 000 mm / 39.4" in	1 000 mm / 39.4" in
Order number	92 010 060-B	92 010 061-B	92 010 062-B

02. Connecting bar extension set

for insertion between the standard connecting bars.
For trolleys on page 18-21.

Type	Series K
Length	635 mm / 25" in
Order number	92 010 157-B

03. Extended connecting bar

for trolleys JFB 6 K up to JFB 14 K.

Type	Series K
Length	per customer request
Order number	92 010 063-B

04. Pulling handle with towing eye

for steerable trolleys JLB 3 K on page 19 and JTLB 6 on page 26.

Type	JLB 3 K
Length	1 120 mm / 44.1" in
Order number	92 010 148-B

05. Extension tandem bar

for trolleys JTLB 6 K / JTLB 14 K on page 26.

Type	JTLB 6 K	JTLB 14 K
Length	per customer request	per customer request
Order number	92 010 160-B	92 010 161-B

06. Pulling handle without towing eye

for revolving trolley **JKB** on page 15-17.

Type	JKB 1	JKB 1,5 - JKB 7,5
Length	1 000 mm / 39.4" in	1 120 mm / 44.1" in
Order number	92 060 082-L	92 030 085-L

07. Connecting bar

for revolving trolley **JKB** on page 15-17.

Type	JKB 1	JKB 1,5 / JKB 3	JKB 4 / JKB 6 / JKB 7,5
Length	1 000 mm / 39.4" in	1 200 mm / 47.2" in	2 400 mm / 94.5" in
Order number	92 060 082-V	92 030 085-V	92 040 085-V

08. Pulling handle with a removable handle

for Series K trolleys on page 18-21. Available as complete pulling handle or as retrofit kit for existing pulling handles.

Type	Series K	Series K
	pulling handle complete	handle + bolt
Order number	92 010 122-B	92 090 300-B

09. „Weld-on Cone“ System

Consisting of two modified turntables and two cassette attachments for Series K trolleys.

Type	JLB 3/6/7	JL 9/10/12/14	JFB 6-14
Order number	92 007 070-B	92 007 140-B	92 008 140-B

10. Steering traverse

For easy moving of heavy loads by hand pallet trucks or forklifts.

Type	JLT 3	JLT 15
Load capacity	3 to	15 to
Order number	13 203 000-V	13 215 000-V

Sturdy castors for any application

High quality coatings



Series K



Series K Professional



Series G



Series S



Series H



Series H

JUWathan® plus

JUWathan®

Sketch

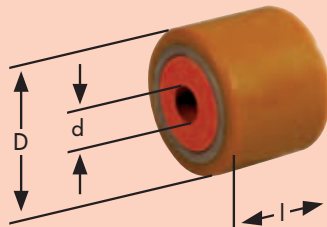

Recommended use

Recommended use for	Castor type and coat		
	JUWathan® JUWathan® plus JUWathan® Professional	JUWAmid	Steel
Plain and clean floors	✓	✓	
For any floors, swarf resistant	✓		
Bad floors with roughness			✓

Details

- **JUWathan® castor design:** The coating is molded around a steel core. Two precision ball bearings are pressed into the steel core.
- **JUWathan® plus castor design:** Based on the JUWathan roller, the new JUWathan-plus castor has a new and improved coating material and a more advanced construction. **NEW:** An aluminum core replaces the steel core for easier handling at the same strength. A polyurethane based lining material is bonded around the aluminum core. This construction reduces the rolling resistance and weight by nearly 30 percent.
- **JUWathan® Professional:** The professional series roller was developed based on the JUWathan plus roller. The side-by-side double roller system provides higher load capacity (2x2 ball bearings) and offers greatly reduced rolling resistance. Turning of the steerable trolley requires less force because the rollers can turn against one another resulting in extremely reduced friction between surface and roller. The much lower friction resistance also causes the rollers on the rear axis to follow in a truer course.

JUWathan® plus	Sketch	Series K*	Series K Professional*	Series G*	
Load capacity		kg / lbs	750 / 1 650	875 / 1 925	1 000 / 2 200
Outside diameter	D	mm / in	85 / 3.3"	85 / 3.3"	140 / 5.5"
Inside diameter	d	mm / in	25 / 1"	25 / 1"	35 / 1.4"
Fitting length	l	mm / in	85 / 3.3"	85 / 3.3"	59 / 2.3"
Weight		kg / lbs	0,85 / 1.9	0,95 / 2.1	1,50 / 3.3
Order-no.			95 050 057-V	95 050 089-D	95 050 047-V

JUWathan®	Sketch	Series S*	Series H*	Series H*	
Load capacity		kg / lbs	1 500 / 3 300	2 100 / 4 620	5 000 / 11 000
Outside diameter	D	mm / in	90 / 3.5"	200 / 7.9"	200 / 7.9"
Inside diameter	d	mm / in	35 / 1.4"	70 / 2.8"	70 / 2.8"
Fitting length	l	mm / in	120 / 4.7"	85 / 3.3"	170 / 6.7"
Weight		kg / lbs	1,75 / 3.9	8,5 / 18.7	18 / 39.7
Order-no.			95 050 025-V	95 050 090-V	95 050 053-V

*We grant 5 years of warranty on operability of our wheels except improper use or normal abrasion.

Our products are also available in galvanized steel

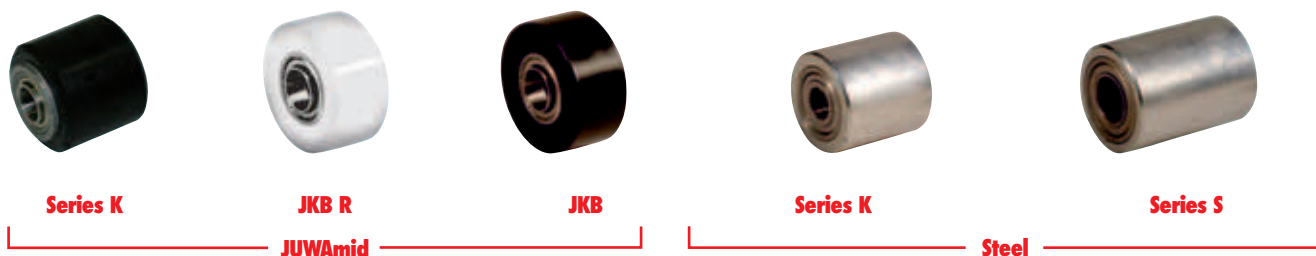

Details

- **JUWAmid castor design:** The coating is molded around a steel core. Two precision ball bearings are pressed into the steel core.
- **Steel castor design:** The steel body is made of a seamless steel tube. Two ball bearings are pressed into the body.

Sketch

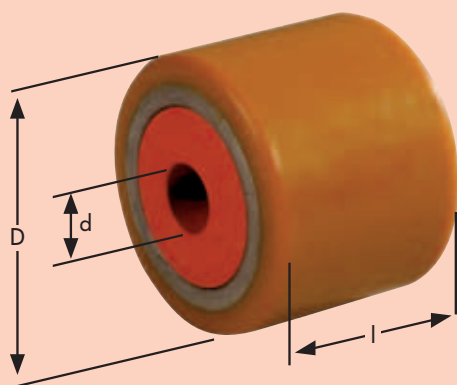

Steel	Sketch		Series K	Series S
Load capacity		kg/lbs	750 / 1 650	1 500 / 3 300
Outside diameter	D	mm/in	85 / 3.3"	90 / 3.5"
Inside diameter	d	mm/in	25 / 1"	35 / 1.4"
Fitting length	l	mm/in	85 / 3.3"	120 / 4.7"
Weight		kg/lbs	2,40 / 5.3	2,85 / 6.3
Order-no.			95 050 043-S	95 050 026-S

JUWAmid	Sketch		JKB	JKB R	Series K
Load capacity		kg/lbs	375 / 825	375 / 825	750 / 1 650
Outside diameter	D	mm/in	85 / 3.3"	85 / 3.3"	85 / 3.3"
Inside diameter	d	mm/in	25 / 1"	25 / 1"	25 / 1"
Fitting length	l	mm/in	43 / 1.7"	43 / 1.7"	85 / 3.3"
Weight		kg/lbs	0,3 / 0.7	0,3 / 0.7	1 / 2
Order-no.			95 050 088-P	95 050 091-P	95 050 023-P