



Revolving Transport Trolley JKB

For loads up to 6 metric tons



JKB 1,5



JKB 3

Available with:

JUWAmid-coated



for level and clean floors
Order number 95 050 088-P

Available with:

JUWathan[®] plus-coated aluminium core



for any floors
Order number 95 050 131-V

Example for load distribution on 9 tons JKB 3 Set:

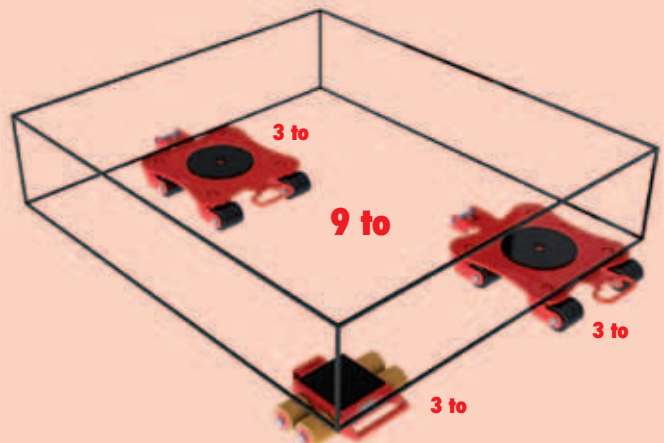

Please refer to page 32-33 for additional roller information

Sketch JKB 1,5

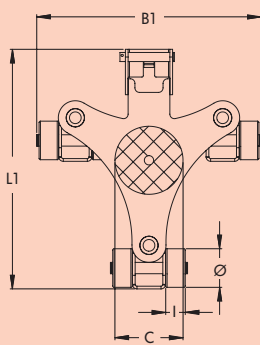

Sketch JKB 3

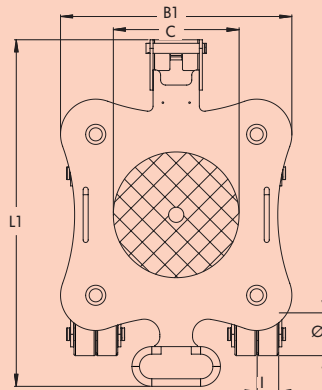

360° rotation in all directions

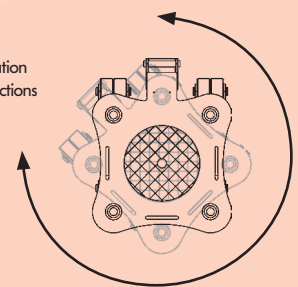

Inspection accordingly technical regulation ANSI/ASME (USA)

Load weight up to		1,5 metric to	3 metric to	3 metric to	6 metric to
Type	Sketch	JKB 1,5 K	JKB 1,5 Set	JKB 3 K	JKB 3 Set
composed of		1 x JKB 1,5 K	2 x JKB 1,5 K	1 x JKB 3 K	2 x JKB 3 K
Load capacity	kg / lbs	1 500 / 3 300	3 000 / 6 600	3 000 / 6 600	6 000 / 13 200
Number of castors	pcs	6	2 x 6	8	2 x 8
Castor dimensions	Ø x l mm / in	85 x 43 / 3.4 x 1.7"	85 x 43 / 3.4 x 1.7"	85 x 43 / 3.3 x 1.7"	85 x 43 / 3.3 x 1.7"
Fitting height	mm / in	110 / 4.4"	110 / 4.4"	110 / 4.3"	110 / 4.3"
Supporting surface of turntable	Ø C mm / in	250 / 10"	250 / 10"	250 / 9.8"	250 / 9.8"
Cassette dimensions	L1 x B1 mm / in	575 x 460 / 23 x 18.4"	575 x 460 / 23 x 18.4"	575 x 460 / 22.6 x 18.1"	575 x 460 / 22.6 x 18.1"
Weight JUWAmid	kg / lbs	20 / 4.4	40 / 88	30 / 66	60 / 132
Order-no. with JUWAmid		14 015 085-P	14 015 085-D	14 030 085-P	14 030 085-D

Revolving transport trolley JKB

For loads up to 12 metric tons



JKB 4



JKB 6

Available with:

JUWAmid-coated



for level and clean floors
Order number 95 050 088-P

Available with:

JUWathan[®] plus-coated aluminium core



for any floors
Order number 95 050 131-V

▶ Please refer to page 32-33 for additional roller information



JKB in action

Sketch JKB 4

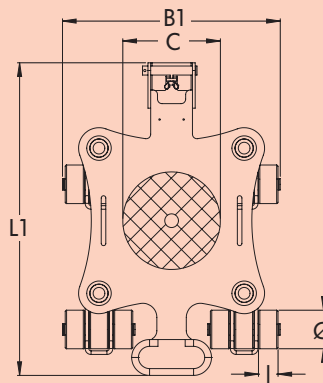

Sketch JKB 6

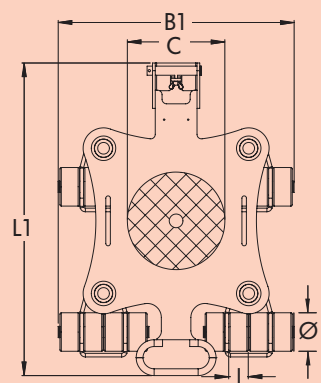

360° rotation
in all directions

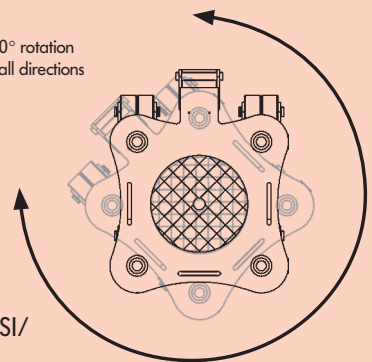

▶ Inspection accordingly
technical regulation ANSI/
ASME (USA)

Load weight up to		4 metric to	8 metric to	6 metric to	12 metric to
Type	Sketch	JKB 4 K	JKB 4 Set	JKB 6 K	JKB 6 Set
composed of		1 x JKB 4 K	2 x JKB 4 K	1 x JKB 6 K	2 x JKB 6 K
Load capacity	kg / lbs	4 000 / 8 800	8 000 / 17 600	6 000 / 13 200	12 000 / 26 400
Number of castors	pcs	12	2 x 12	16	2 x 16
Castor dimensions	Ø x l mm / in	85 x 43 / 3.3 x 1.7"	85 x 43 / 3.3 x 1.7"	85 x 43 / 3.3 x 1.7"	85 x 43 / 3.3 x 1.7"
Fitting height	mm / in	110 / 4.3"	110 / 4.3"	110 / 4.3"	110 / 4.3"
Supporting surface of turntable	Ø C mm / in	250 / 9.8"	250 / 9.8"	250 / 9.8"	250 / 9.8"
Cassette dimensions	L1 x B1 mm / in	690 x 475 / 27.2 x 18.7"	690 x 475 / 27.2 x 18.7"	690 x 525 / 27.2 x 20.7"	690 x 525 / 27.2 x 20.7"
Weight JUWAmid	kg / lbs	43 / 95	86 / 189	44 / 97	88 / 194
Order number with JUWAmid		14 041 085-P	14 041 085-D	14 061 085-P	14 061 085-D

Revolving transport trolley JKB

For loads up to 15 metric tons



JKB 7,5



Sketch JKB 7,5

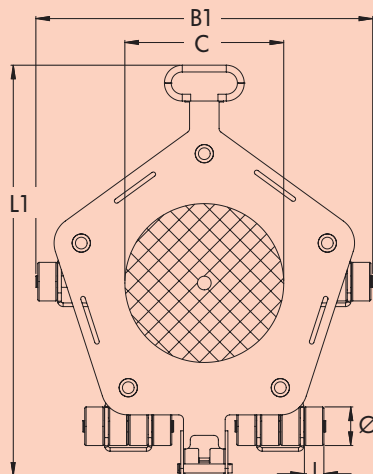

Inspection accordingly technical regulation ANSI/ASME (USA)

Advantages in detail

- Optional connecting bars can be fixed without tools by clamping down on handle.
- High load capacity at low weight.
- Bearing supported swivelling rollers allow 360° maneuverability.
- Same height trolleys provide interchangeability. Mix and match revolving trolleys with Series K transport trolleys.
- All products in a set also available with accessories listed on page 31.
- Unrivalled: The double roller system reduces rolling and turning resistance to a minimum.
- Using the slits in the platform the trolleys JKB 3-7,5 can be affixed to the load with standard tiedown belts.
- In addition, all the trolleys are outfitted with a platform center hole to allow attachment to the load.
- For choosing the adequate revolving trolley we recommend a load of two-third of the maximum capacity. This will be the most advantageous compromise between load, ergonomic and handling of the equipment.

Please see page 31 for compatible connecting bars and pulling handles

Load weight up to		7,5 metric to	15 metric to
Type	Sketch	JKB 7,5 K	JKB 7,5 Set
composed of		1 x JKB 7,5 K	2 x JKB 7,5 K
Load capacity	kg / lbs	7 500 / 16 500	15 000 / 33 000
Number of Castors	pcs	20	2 x 20
Castor dimensions	Ø x l mm / in	85 x 43 / 3.3 x 1.7"	85 x 43 / 3.3 x 1.7"
Fitting height	mm / in	110 / 4.3"	110 / 4.3"
Supporting Surface of turnable	Ø C mm / in	250 / 9.8"	250 / 9.8"
Cassette dimensions	L1 x B1 mm / in	910 x 660 / 35.8 x 26.0"	910 x 660 / 35.8 x 26.0"
Weight with JUWAmid	kg / lbs	63,5 / 140	127 / 280
Order number with JUWAmid		14 075 085-P	14 075 085-D